

Final Exam for CSE 271 Sections (3) and (4) Fall 2005

12- 12-2005, 12:20P-2:10P, 100 LIFE SCI, 009 LIFE SCI

Dr Kabekode V. Bhat, Associate Professor of Computer Science & Engineering, The Pennsylvania State University 111D, Information Sciences & Technology Building, University Park, PA 16802, (814) 863 0147 (Tel), kbhat@cse.psu.edu

Answer all questions in the space provided Use back of the page if more space needed. (Total 40 points)

1a Using a 74164 shift register shown below, design a system that produces an output of 1 when the last 9 inputs (input x = AB) were 0. Show the circuit diagram. (7 points)

Figure 8.5 74164 serial-in parallel-out shift register.

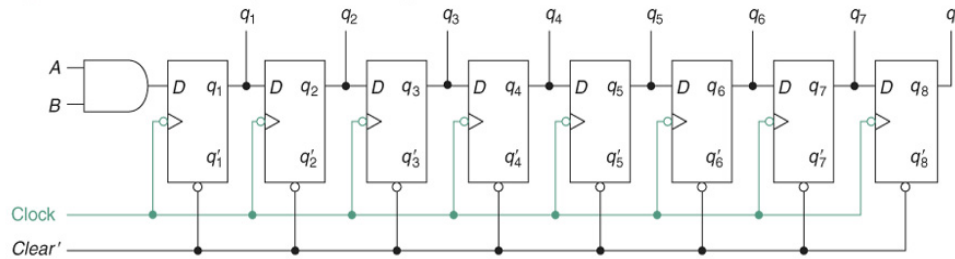

1 b. What is a bus? Provide a circuit to implement a bit of a bus between two systems (say A and B) using three-state gates. (2 points)

2. Design a system using the 74161 counter that produces a 1 output when the input has been 1 for at least 12 consecutive clock times. (8 points)

3 The 74161 counter.

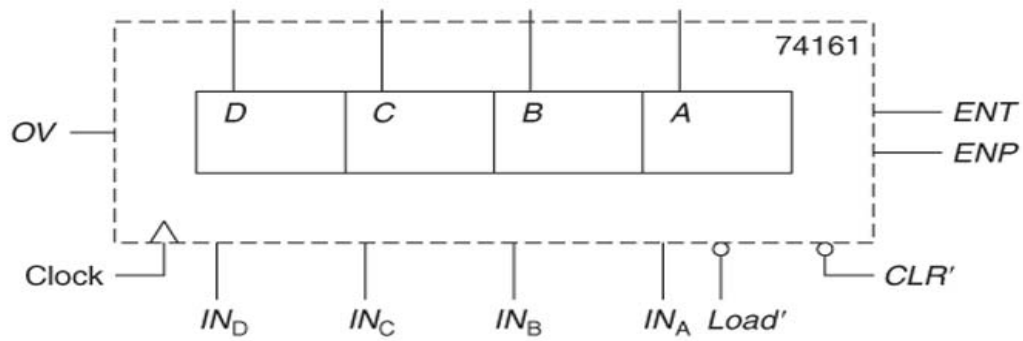

3. For the following circuit, write the flip flop and output equations and construct the complete state table. (8 points)

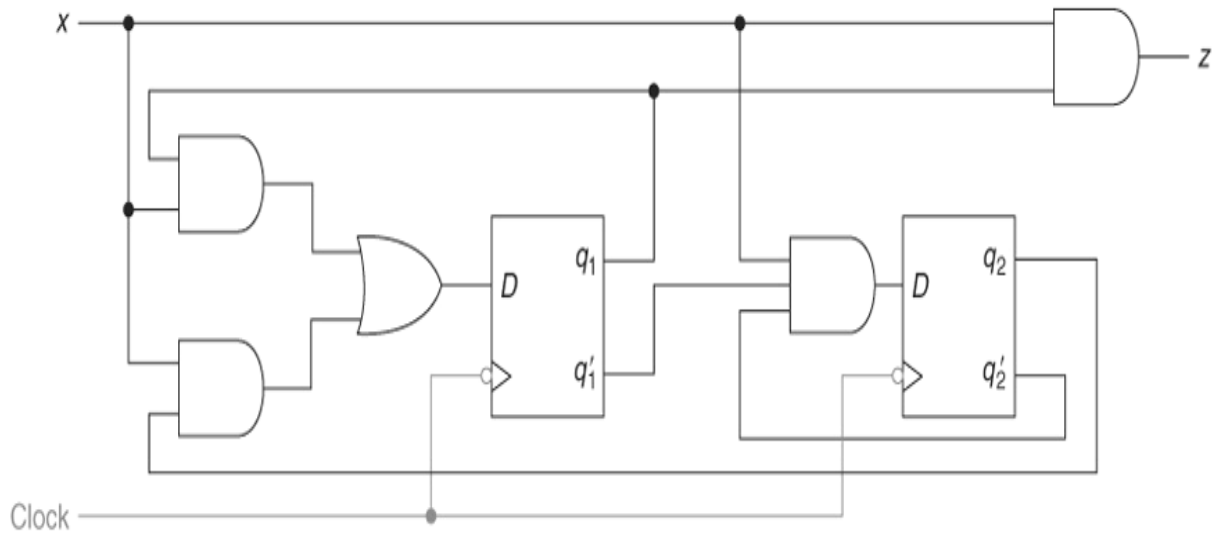

4a. x and z are the input and output for a circuit that uses 2 D flip flops (trailing edge clock inputs). The following circuit equations are given for the D flip flops 1 and 2:

$$D_1 = xq_2 + xq_1$$

$$D_2 = xq_2' + xq_1$$

and for the output $z = q_1q_2$

Draw the diagram for the circuit that uses the two D flip flops and AND and OR gates as needed. Verify that the circuit that you designed is correct. (4 pts)

4b Design a 2 bit asynchronous counter and explain how it works (2 pts). Assuming all states in this circuit are initially zero, show the timing delay in the asynchronous counter (1 points)

5a. Draw the circuit diagram for a simple 4-bit shift register using SR flip flops and explain how it works (2 pts). Draw the shift register timing diagram for an input sequence $x = 10111000$. Assume that all flip flops are initially 0. (2 pts)

5b. For the following state table, draw the corresponding state diagram (label correctly) (2pts).

q	q^*		z	
	$x = 0$	$x = 1$	$x = 0$	$x = 1$
0 0	0 0	0 1	0	0
0 1	0 0	1 0	0	0
1 0	0 0	1 0	0	1
1 1	0 0	1 0	0	1

5c The state table given below is for a _____ sequential circuit. (Fill in)? (1 pt)

q	q^*		z	
	$x = 0$	$x = 1$	$x = 0$	$x = 1$
0 0	0 0	0 1	0	0
0 1	0 0	1 0	0	0
1 0	0 0	1 0	0	1
1 1	0 0	1 0	0	1

For a given input sequence $x = 0\ 1\ 1\ 0\ 1\ 1\ 1\ 1\ 0$
 provide the timing trace for the circuit associated with the state table. (Note $q = q_1\ q_2$)
 (1pt)

x 0 1 1 0 1 1 1 1 0

q_1

q_2

z

Draw the timing diagram for an extra point!