

HW#2 Sum07

#1.

The closed tank in Fig. is at 20°C . If the pressure at point A is 95 kPa absolute, what is the absolute pressure at point B in kPa? What percentage error do you make by neglecting the specific weight of the air?

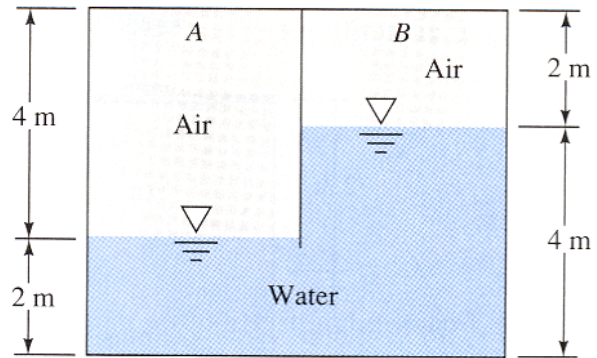

#2.

Water ($\gamma_1 = 62.4 \text{ lb/ft}^3$) flows in a pipe. If the manometer connected as shown is used with mercury as the fluid ($\gamma = 850 \text{ lb/ft}^3$) and h is 5 inches when the level B is 15 inches above the centerline of the pipe, what is the pressure in the pipe?

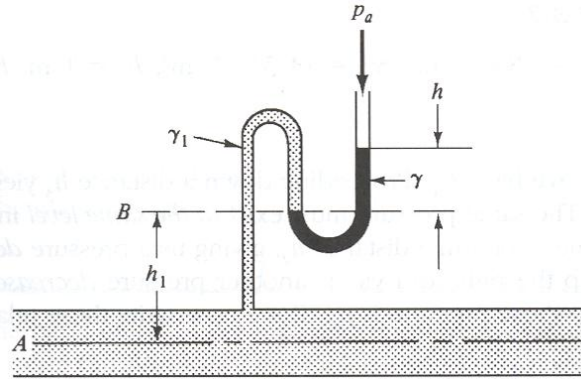

#3.

A three-fluid manometer such as shown in the Fig. is to be used to measure large pressure differences. Assuming that the same liquid is in the legs with $\gamma_1 = \gamma_2 = 62.4 \text{ lb/ft}^3$ (water) and that the manometer fluid is mercury ($\gamma_3 = 850 \text{ lb/ft}^3$), determine the pressure difference between A and B if y is equal to 1 ft and (a) A and B are at the same level. (b) A is 6 inches higher than B.

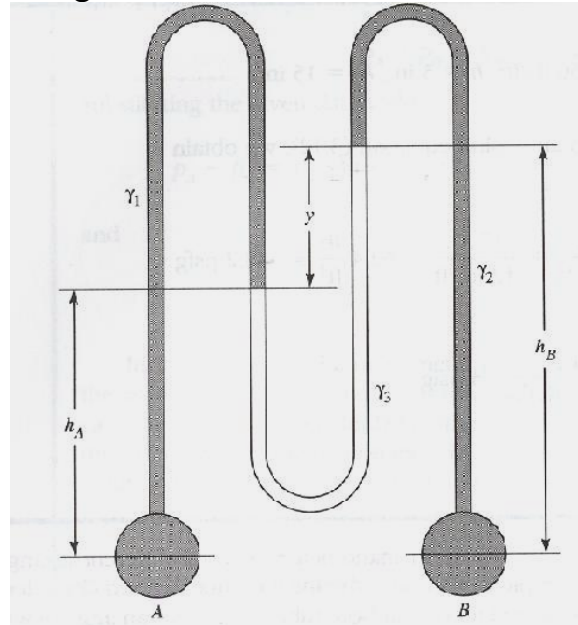

#4

Water flows upward in a pipe slanted at 30° , as in Fig. The mercury manometer reads $h = 12$ cm. Both fluids are at 20°C . What is the pressure difference $p_1 - p_2$ in the pipe?

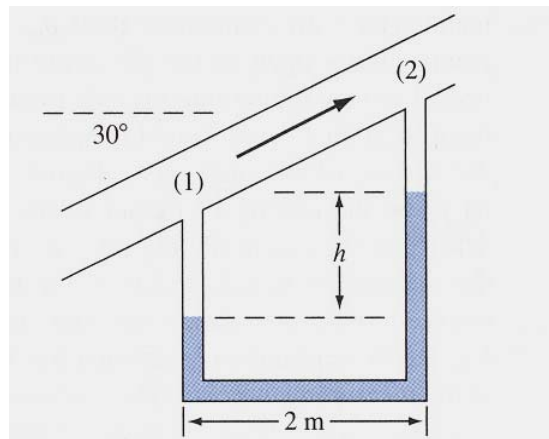

#5.

Determine the pressure at point A for the inclined manometer shown.

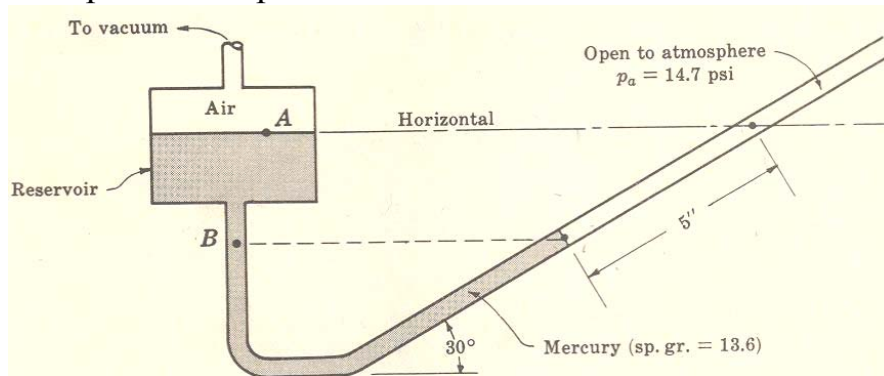

#6.

Water flows through a nozzle as shown in the Fig. Determine the height h if the gage pressure at A is 5 psi.

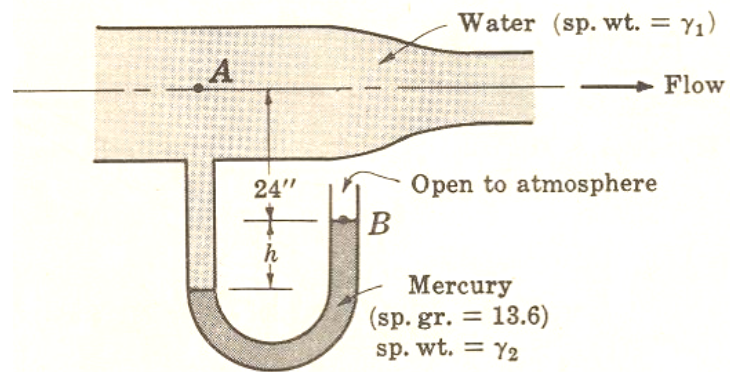

#7.

Determine the total force required to keep the dam gate, shown below, from opening. The gate is 5 ft wide.

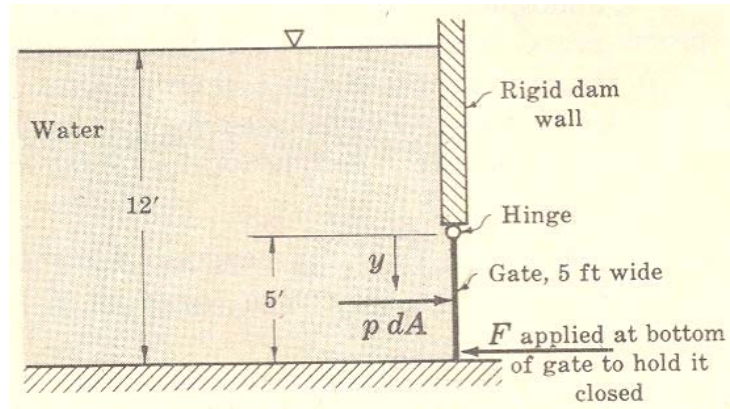

#8.

Determine the force F_B due to water pressure on the inclined surface shown. The surface is hinged at the top and is 3 m wide.

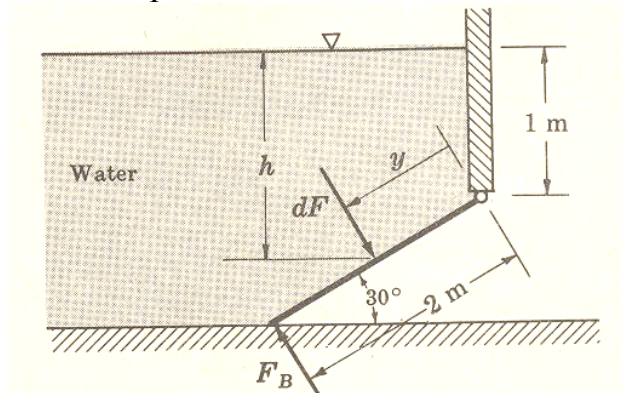

#9.

As shown in Fig., a vertical plane extends from the surface of water on one side to a depth of 10 m. On the other side there is water to within 2 m of the top. If the plate is 5 m wide, what is the net force on the plate?

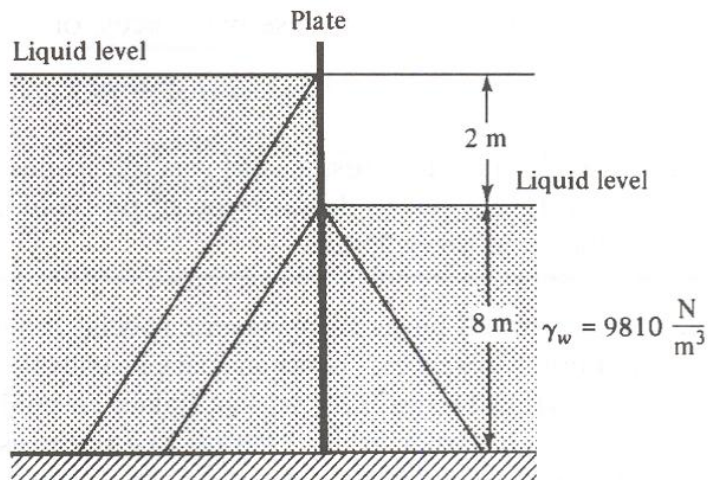

#10.

The tank shown has a 4-cm-diameter plug at the bottom on the right. All fluids are at 20°C. The plug will pop out if the hydrostatic force on it is 25 N. For this condition, what will be the reading h on the mercury manometer on the left side?

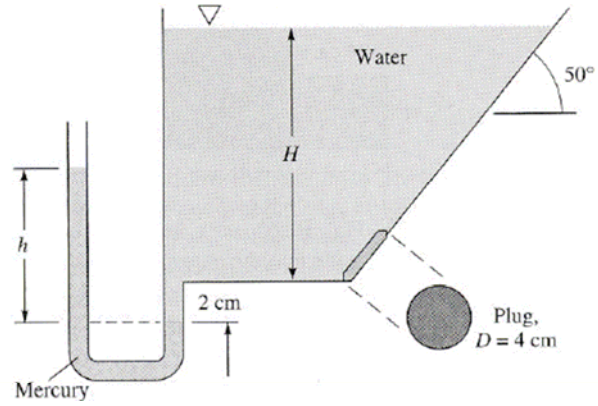

#11

The dam shown is a quarter circle 50 m wide into the paper. Determine the horizontal and vertical components of the hydrostatic force against the dam.

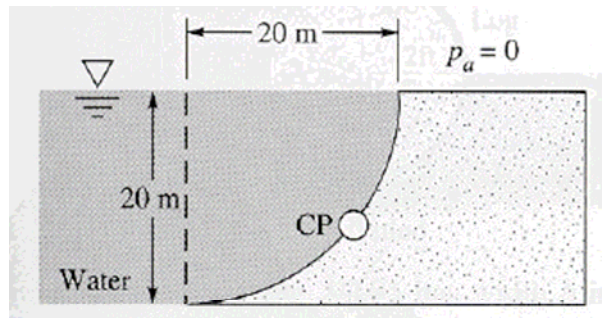

#12

The *spar buoy* is a buoyant rod weighted to float and protrude vertically, as in Fig. It can be used for measurements or markers. Suppose that the buoy is maple wood (SG = 0.6), 2 in \times 2 in \times 12 ft, floating in seawater (SG = 1.025). How many pounds of steel (SG = 7.85) should be added to the bottom end so that $h = 18$ in?

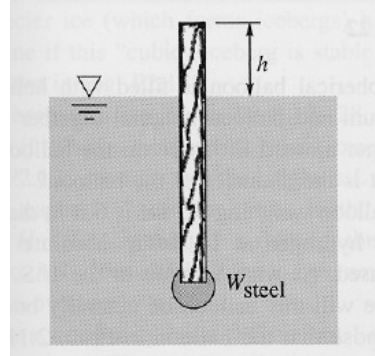

#13

The uniform 5-m-long round wooden rod shown below is tied to the bottom by a string. Determine (a) the tension in the string and (b) the specific gravity of the wood. Is it possible for the given information to determine the inclination angle θ ? Explain.

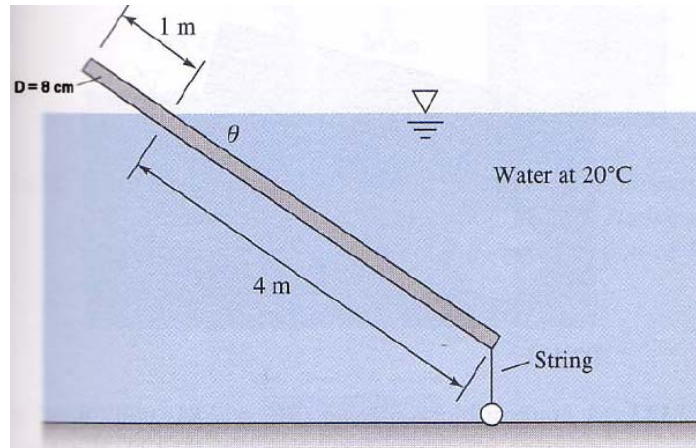

#14

The uniform beam shown below has the dimensions $L \times h \times b$ and with the specific weight γ_b , floats exactly on its diagonal when a heavy uniform sphere is tied to the left corner. Show that this can happen only (a) when $\gamma_b = \gamma/3$ and (b) when the sphere has size

$$D = \left[\frac{Lhb}{\pi(SG - 1)} \right]^{1/3}$$

